

1. Introduction

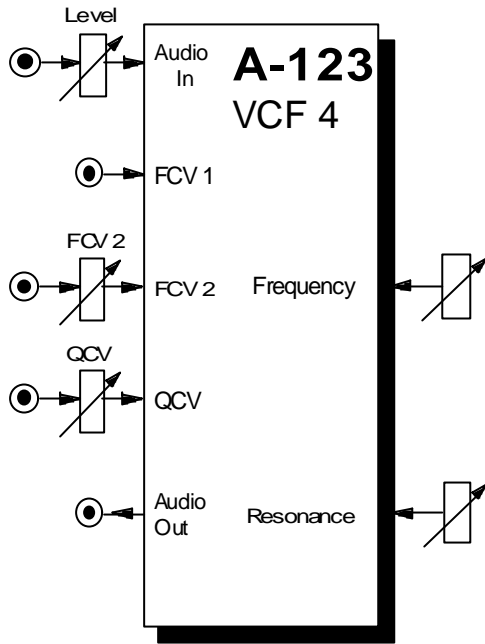

Module **A-123 (VCF 4)** is a **voltage-controlled high-pass filter**, which filters out the lower parts of the sound spectrum, and lets higher frequencies pass through.

The **cut-off frequency** determines the point at which filtering takes effect. You can control this manually, or by voltage control (**filter modulation**, for instance by an LFO). Two CV inputs are available.

The cut-off slope is **-24 dB/octave**. The circuitry uses a Curtis CEM 3320 chip.

Voltage controlled resonance: on the VCF 4, resonance can be controlled not just manually, but by voltages as well, right up to self-oscillation. In this case, the filter behaves like a sine wave oscillator.

2. VCF 4 - Overview

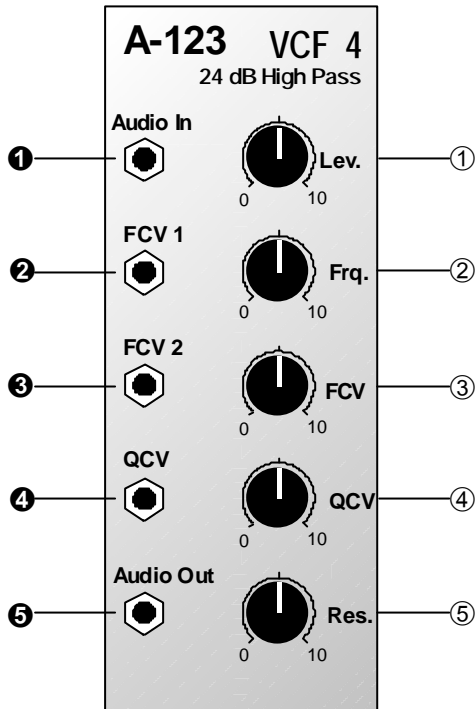

Controls:

- 1 **Lev.** : Attenuator for audio input !
- 2 **Frq.** : Cut-off frequency control
- 3 **FCV** : Attenuator for filter CV at input §
- 4 **QCV** : Attenuator for resonance CV at input \$
- 5 **Res.** : Control for setting the filter's resonance (emphasis)

In / Outputs:

- ! **Audio In** : Input to the filter
- " **FCV 1** : Input for voltage control of the filter cut-off frequency (1 V /octave)
- § **FCV 2** : ditto, level controlled by 3
- \$ **QCV** : Input for voltage control of the filter's resonance; level controlled by 4
- % **Audio Out** : Output from the filter

3. Controls

1 Lev.

Use this attenuator to control the amount of signal entering the filter input §.

H If the filter's output sounds distorted, turn this control down, unless you deliberately want the sound as a special effect.

2 Freq.

With this control you adjust the **Cut-Off Frequency** f_c , below which the filter attenuates all frequencies.

At zero, the filter is fully open. The more you turn the filter up, the more the low frequencies are filtered (see Fig. 1): the sound becomes thinner and less solid, until at 10 the filter is completely shut, and blocks off all frequencies below 15kHz. Frequencies above 15kHz are still let through, but are generally outside normal adult hearing range.

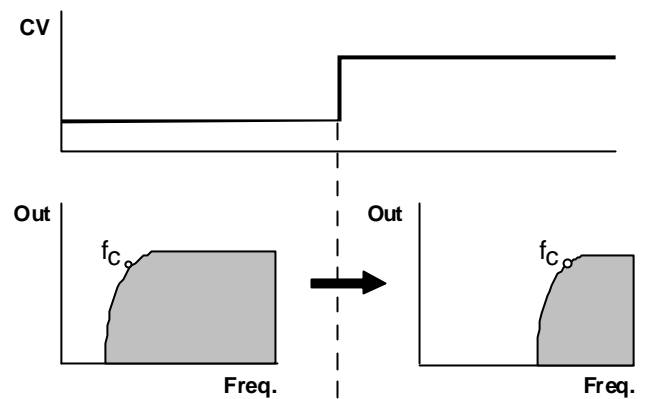

Fig. 1: White noise put through a high pass filter

3 FCV

For voltage control or modulation of the cut-off frequency using CV input § (see Fig. 1), use attenuator 3 to control the **level of voltage control**.

4 QCV

Attenuator 4 gives you control over the **level of voltage control** applied to resonance.

5 Res.

With this control you adjust the filter's **resonance** (or 'emphasis') - the parameter which emphasises the frequencies around the cut-off point f_c (see Fig. 2). It strengthens or emphasises the band of frequencies around the filter's cut-off point.

At close to maximum resonance, the filter starts to self-oscillate, and behaves like a **sine wave oscillator**. Thanks to this effect, you can use the filter as an independent tone source.

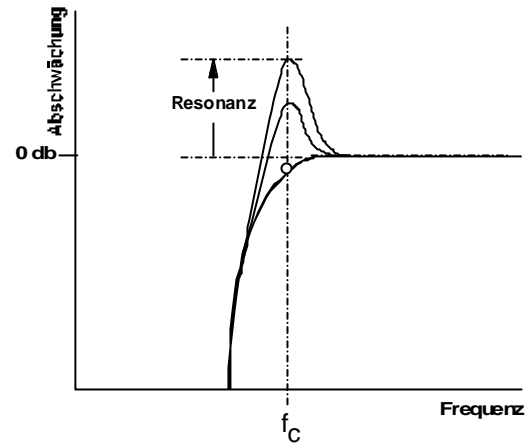

Fig. 2: How resonance affects the behaviour of a high pass filter.

4. In / Outputs

! **Audio In**

This is the filter's **audio input** socket, where you patch in the output from any sound source.

" **FCV 1**

Socket FCV 1 is a **voltage control input** for the filter. It works on the 1V / octave rule, like the VCOs.

If you connect the output of a modulation source (eg LFO, ADSR) to this input, the cut-off frequency of the filter will be modulated by its voltage: ie, the sound color changes according to the voltage put out by the modulator.

P If you use this VCF as a sine wave oscillator, connect a pitch control voltage to this input. Do the same if you want the filter's cut-off frequency to track exactly with the pitch of a note.

§ **FCV 2**

Socket § is also a **voltage-control input** for the filter. Unlike on socket " , though, you can adjust the level of voltage by using the attenuator 3, and thus control the intensity of modulation effect on the filter.

\$ **QCV**

This socket is the **voltage control input** for the filter's **resonance**.

If you patch a modulation source (eg LFO, ADSR) to this input, the resonance of the filter will be modulated by it: increases in voltage will increase the amplitude of the frequencies around the filter cut-off point.

% **Audio Out**

Filter output % sends out the filtered audio signal.

5. User examples

The filter's cut-off frequency can be modulated in various ways:

- **VCF - LFO**

Modulation of the cut-off frequency produces cyclical changes of the **sound spectrum**. At low frequencies (c. 1 - 5 Hz), you get a **"Wah-Wah"-effect**. Modulation in the audio range produces interesting sounds; the same principles apply here as with frequency modulation of the A-110 VCO (see chapter 6).

- **VCF - ADSR**

Modulation by an envelope results in gradual change of the **sound spectrum**. Typical uses include **filter sweeps**, which slowly sweep through the audio spectrum, picking out different harmonics in turn.

- **VCF - Keyboard CV**

This modulation produces pitch-related filter opening.

24 dB notch filter with voltage control of middle frequency and bandwidth

The patch in Fig. 3 shows a 24 dB notch filter with voltage-controlled middle frequency and bandwidth.

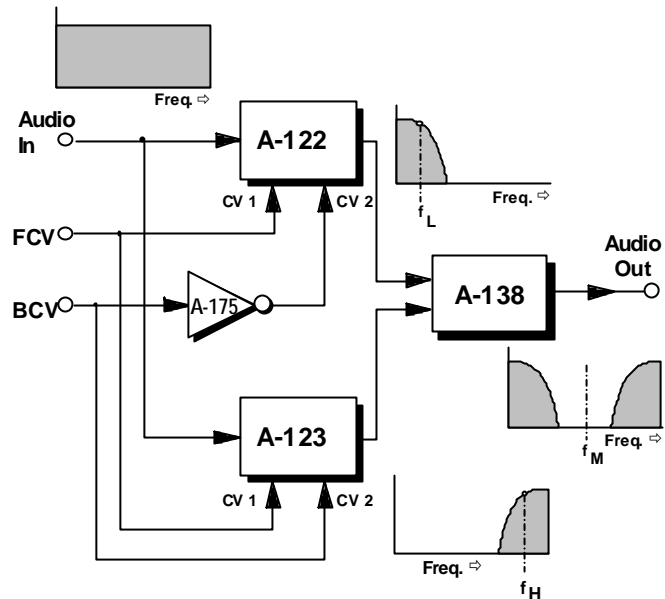

Fig. 3: 24 dB notch filter with voltage control of middle frequency and bandwidth.

For this patch, set both f_L (Low Pass A-122) and f_H (High Pass A-123) to roughly equal cut-off points (judging by ear).

Use a control voltage "FCV" to alter the middle frequency f_M of the notch filter: $f_M = (f_L + f_H) / 2$.

Use a control voltage "BCV" to alter the bandwidth, which is determined by how far apart the two filters' cut-off frequencies are. Using the A-175 Voltage Inverter, these frequencies f_L and f_H are altered symmetrically around the middle frequency (see Fig. 4).

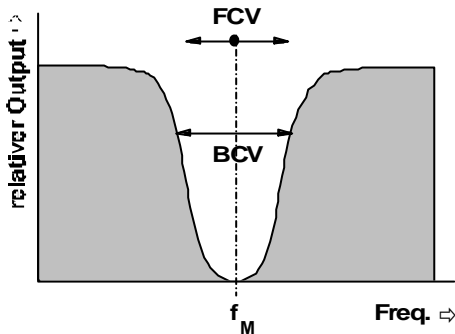

Fig. 4: Effect of FCV and BCV on the notch filter's response.

H

To create a **24 dB bandpass filter** with voltage-controlled middle frequency and bandwidth, put both filters in series (see the A-122 user examples). For voltage control of middle frequency and bandwidth, follow the relevant notch filter instructions. (see Fig. 5).

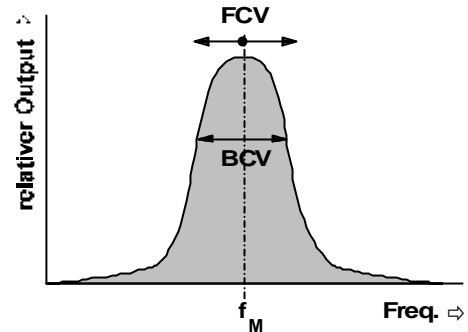

Fig. 5: Effect of FCV and BCV on the band pass filter response.

6. Patch-Sheet

The following diagrams of the module can help you recall your own **Patches**. They're designed so that a complete 19" rack of modules will fit onto an A4 sheet of paper.

Photocopy this page, and cut out the pictures of this and your other modules. You can then stick them onto another piece of paper, and create a diagram of your own system.

Make multiple copies of your composite diagram, and use them for remembering good patches and set-ups.

- P
- Draw in patchleads with colored pens.
 - Draw or write control settings in the little white circles.

